

SELF SERVICE FM



EN Diesel fuel dispensers with multi-user meter

From a careful examination of growing customer needs, this innovative range of distributors has seen the light, characterised by great sturdiness and elegant design, dispensing speed and precision. Organised data control with selection of authorised operating staff, PC linkup with exporting of data and issuing of ticket by local printer, tank level indicator, water absorption filter to ensure quality of dispensed product, hinged front door, (with lock) for easy access to internal component parts.

Performance

- Flow rates from 70 to 90 l/min.
- Pre-selection dispensing.
- +/- 0.5 % precision within the flow-rate range.
- Able to control from minimum 50 to max 120 users.
- Local memory up to the last 255 performed dispensing operations.
- Possibility of entering vehicle registration number and kilometres (odometer).
- Dispensing date and time control.
- Possibility of linking to PC and exporting data at a distance of up to 1000 m.
- Dedicated software with possibility of printing summary dispensing details for users.
- Local printer with issuing of ticket

at end of dispensing operation (with date and time) and possibility of locally printing details of dispensing operations performed.

- By level indicator, possibility of continuous display of tank contents or level.
- Minimum tank level pump stop.
- Magnetic key for user recognition.

Construction features

- Blade pump with incorporated bypass.
- Induction motor featuring cutout for overheating
- Pump suction mesh filter
- Water separator filter (optional).

- By-Pass emergency filter included, to guarantee the working operation while replacing the filter.
- Pulser meter with oval gears.
- Automatic nozzle with swivel connector and 4-metre diesel fuel hose.
- Electronic unit with keyboard and display for entering registration numbers.
- Local printer.
- Level gauge (optional).

Available:

Dedicated software with possibility of printing summary dispensing details for users.

Users 120

Flow rate up to 90 l/min

Accuracy +/- 0,5%

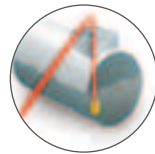

Level indicator integrated

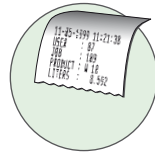

Ticket printer integrated

SelfService Desk (optional)

The software arranges dispensing data for analysis and print out.

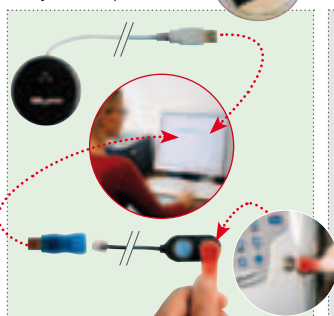

Kit H2O filter



Column version

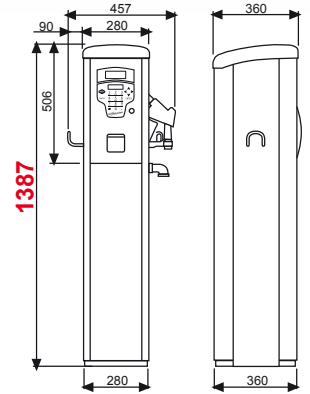

Tank version

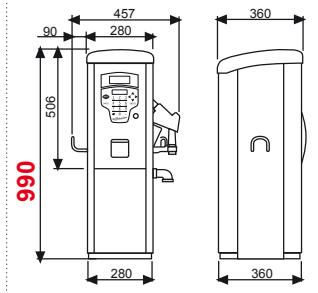

Code	Description	Pump	Flow rate		AC		Meter	I	Micro	H ₂ O filter	PC	Users	Nozzle	Weight Kg	Packaging mm
			l/min	gal/min	Volt/Hz	Watt									
Column versions															
F0073900B	Self Service 70 FM	Panth 72	70	18	230/50	900	K600	1"1/2	30	•	•	120	A	67	1485x500x420
F0074200B	Self Service 100 FM	E 120	90	24	230/50	1150	K600	1"1/2	30	•	•	120	A	75	1485x500x420
Tank versions															
F00739B0B	Self Service 70 FM Tank	Panth 72	70	18	230/50	900	K600	1"1/2	-	-	•	120	A	57	1100x500x420
F00742B0B	Self Service 100 FM Tank	E 120	90	24	230/50	1150	K600	1"1/2	-	-	•	120	A	65	1100x500x420

Upon request it is available with different tension and 60 Hz frequency

Available:
F00611010 Kit filter 70 l/min external
F00611020 Kit filter 150 l/min external

