



First choice when
quality counts.

700 Series High Volume Hose Reel



Bare Reel

**Superior
design with
heavy-duty
ball bearings
and hose
lengths to
75 ft. (23 m)**



Overhead Mount

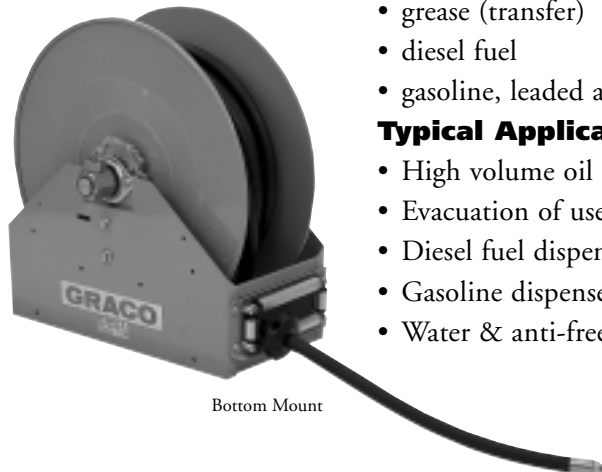

Bottom Mount

- **Heavy-duty ball bearings and spring**
- **High flow rate capabilities**
- **Hose lengths to 75 ft. (23 m)**
- **Easy rewind with minimal manual hose guiding required**

The 700 Series high volume oil dispensing hose reel is ideally suited for evacuation of used oil and dispensing or transferring lubricants, gasoline or diesel fuel. This reel will accommodate hoses up to 75 ft. (23 m) long for outstanding range, especially for oil transfer or dispense applications on mobile lube trucks. Superior design features include heavy-duty ball bearings which will far outlast sleeved bearings used on competitive hose reels. The clevice type spring connections will ensure dependable service and easier rewind than any other reel on the market. This is the largest capacity reel in the extensive Graco product line and it is backed with the best warranty in the industry.

Typical Fluids Handled

- motor oil
- gear lube
- water
- anti-freeze
- automatic transmission fluid
- hydraulic oil
- synthetic oils
- grease (transfer)
- diesel fuel
- gasoline, leaded and unleaded

Typical Applications

- High volume oil dispense
- Evacuation of used oil
- Diesel fuel dispense or transfer
- Gasoline dispense or transfer
- Water & anti-freeze dispense or transfer

Ordering Information

All product offerings with hoses will be offered as an unassembled package that includes 3 boxes: (1) hose reel, (2) hose and (3) ball stop and fitting kit.

237-728 Bare Reel

Hose Reel Packages for Oil Dispense

237-875 w/ 1/2 in. x 75 ft. hose,
1500 psi (103 bar)

237-876 w/ 1/2 in. x 20 meter hose
1500 psi (103 bar)

237-877 w/ 5/8 in. x 75 ft. hose,
1500 psi (103 bar)

237-878 w/ 5/8 in. x 20 meter hose,
1500 psi (103 bar)

237-879 w/ 3/4 in. x 75 ft. hose
1500 psi (103 bar)

237-880 w/ 3/4 in. x 20 meter hose
1500 psi (103 bar)

237-881 w/ 3/4 in. x 50 ft. hose
1500 psi (103 bar)

Hose Reel Packages for Oil Evacuation/Dispense

237-882 w/ 1 in. x 50 ft. hose
24 in. Hg vacuum to 1500 psi (103 bar)

237-883 w/ 1 in. x 30 ft. hose
24 in. Hg vacuum to 1500 psi (103 bar)

Hose Reel Package for Fueling

237-884 w/ 1 in. x 50 ft. hose
150 psi (10 bar)

Dimensions

- A** 10.45 in. (265 mm)
mounting holes,
center to center
- B** 22.25 in. (565 mm)
mounting holes,
center to center
- C** 11.83 in. (300 mm)
- D** 24.00 in. (609 mm)
- E** 24.75 in. (628 mm)
- F** 25.00 in. (635 mm)
Diameter of reel
- G** 13.63 in. (346 mm)
- H** 15.5 in. (394 mm)

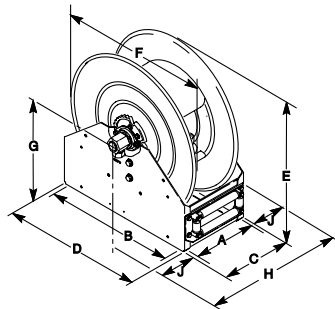

Technical Specifications

Medium Pressure Hose Reel

Porting size

Inlet 1 npt(f)

Outlet 1 npt(f)

Max. pressure 1500 psi (103 bar)

Max. vacuum 24 in. Hg

Operating temperature -10°-105°F (-12°-41°C)

Bearings sealed, self aligning ball bearings

Wetted parts carbon steel, Viton®

Dimension 25 in. L x 15.5 in. W x 26.1 in. H
(635 mm L x 394 mm W x 663 mm H)

Weight 103 lbs. (47 kg)

Instruction manual 308-546

Viton® is a registered trademark of Du Pont.

Accessories

237-944 Roller Support Kit

For overhead reels mounting. See illustration to the right.

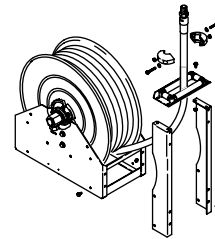

237-932 Overhead Mounting Hardware Kit

Includes 2 brackets.

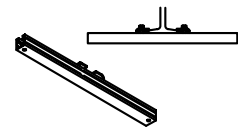

Repair Kits

237-901 Repair Kit

For medium pressure hose reel 237-728. Includes swivel service parts only.

Sales/Distribution

Toll Free 800-367-4023

Contact sales personnel
Locate authorized distributors
Product information literature



GRACO INC.
P.O. Box 1441
Minneapolis, MN 55440-1441

© 1995 Graco Inc. Form No. 305-734 7/95 Printed in the U.S.A.

Any and all specifications contained herein are subject to change without notice.



Graco's products are designed and manufactured under ISO 9000 / EN 29000 registered quality systems.

