

TE055
0107
0009



R100 POWER-FLO / R300 PRESSURE-FLO

AIR OPERATED OIL PUMPS

INSTRUCTION MANUAL

Thank you for purchasing a Macnaught Air operated Oil Pump.

The Macnaught range of 1:1 and 3:1 Ratio Oil Pumps are designed to reliably dispense various types of lubricating oils.

Macnaught Ratio Oil Pumps are suitable for use with engine oil, gear oil, automatic transmission fluid and anti-freeze/anti-boil or compatible fluids.

Macnaught also manufacture a complete range of retractable oil hose reels, oil dispensing nozzles, fuel pumps, oil pumps, positive displacement flowmeters, greasing equipment and a complete range of accessories.

GENERAL INFORMATION

This manual assists you in operating and maintaining your new R100 Power-Flo or R300 Pressure-Flo oil pump. The information contained will help you ensure many years of dependable performance and trouble free operation.

Please take a few moments to read through this manual before installing and operating your new R100 or R300 ratio oil pump. If you experience problems with this product, refer to the Trouble Shooting sections of this manual. If you require further assistance please contact your nearest Macnaught Distributor. Authorised Macnaught Service Centre.

IMPORTANT INFORMATION



READ THIS INFORMATION CAREFULLY BEFORE USE

Please retain this instruction manual for future reference.

Your safety is important to us. Please read, understand and follow all safety instructions listed below. Some of these instructions alert you to the potential for personal injury. "Cautions" listed throughout the manual advise of potential practices or procedures which may cause damage to your equipment.

Drum pump

Stub pump



Make sure all operators have access to adequate instructions about safe operating and maintenance procedures.

Do not exceed the maximum recommended air inlet pressure of 1035 kPa / 150 psi / 10.3 bar. The pumps require a minimum air inlet pressure of 400 kPa / 60 psi / 4 bar and we recommend that you operate the unit at 690 kPa / 100 psi / 6.9 bar.

Do not strike the unit if it fails to operate. Refer to "Trouble Shooting Guide" or return the unit to your nearest Macnaught distributor or Authorised Macnaught Service Centre.

Use suitable thread sealant (eg. Teflon tape) on all screwed fittings, but do not over tighten to avoid damage.

Never allow any part of the human body to come in front of, or in direct contact with the material outlet. Never point the nozzle of the control gun at yourself or anyone else.

Most accidents occur because of component rupture. Be certain that any and all system components will withstand the pressures being developed. Never exceeded the pressure rating of any component installed in the system.

Before attempting any repairs or maintenance of this product disconnect the air supply and release oil line pressure by operating hand piece / gun trigger.

ASSEMBLY

The R100 Stub Pump has an inlet thread of 1" BSP (1" NPT USA/Canada).

The R300 Stub Pump has an inlet thread of ¾" BSP (3/4" NPT USA/Canada).

Macnaught have a range of telescopic suction tubes and accessories available on request.

If you are installing a stub pump, screw either a Macnaught telescopic suction tube, or an appropriate length of threaded pipe to the inlet port on your pump.

Note: Use suitable thread sealant (e.g. teflon tape) on all threaded pipe connections.

CAUTION

Check that all fittings, including hose clamps are tightened correctly before use

Remove the bung adapter assembly from the pump and screw it into the drum/tank opening.

Carefully lower the pump through the bung adapter and tighten the ring nut firmly.

Connect the appropriate hose and / or dispensing equipment to your pump outlet.

Note: To protect the pump an in-line oiler must be used. It is also recommended that a micro-fine (5 micron) airfilter is fitted to the air inlet of the pump to ensure maximum efficiency of the pump.

Before connecting the air supply, the user should add a "stop" compressed air cock.

Note: The air cock must be a ¼ turn type (allowing quick closure) and should be located close to the body of the pump and be easily recognized. (Macnaught accessory TA16 available on request).

OPERATION

- 1) Ensure the drum or tank is "vented".
- 2) Partially open the on/off air valve. The pump will prime automatically.
- 3) Open the delivery outlet/nozzle. The pump will automatically start.
- 4) Adjust on/off air valve to regulate the flow. Close delivery outlet/nozzle to stop flow.

Caution

Do not run the pump dry. Remember to switch off the air supply if the pump is not being used for extended periods. (e.g. at the end of each working day)

MAINTENANCE

Caution

Before carrying out any maintenance disconnect the air supply and release the fluid pressure in the system.

Inspect your oil pump and associated hoses weekly for any signs of damage. Replace any suspect or damaged parts/components as required.

DISASSEMBLY

Note: Disconnect the air supply and release fluid pressure.

The R100 and R300 pumps have been designed to allow the air motor assembly, and piston rod seal (42) to be serviced without removing the pump from the installation.

To service the air motor and Piston rod seal without removing pump from the installation.

- 1) Disconnect the air supply and release oil line pressure.
- 2) Remove 4 screws (44) and remove the air motor housing (2).
- 3) Remove buffer spring (1) and buffer stopper (3) from air motor housing (2).
- 4) Push the air motor and piston rod assembly downwards into the pump tube (20) to enable easy disassembly of the air motor.
- 5) Remove the three Allen screws (5) and washers (5A) from the air valve assembly, then remove air valve cap (6).
- 6) Lift up the cover (17) to expose the exhaust holes located on the piston rod (41).
- 7) To retain the piston rod (41), insert the correct size steel bar or pin punch into one of the exhaust holes on the piston rod (41).
- 8) Unscrew the piston rod bolt (7), and remove the air valve assembly (8,9,10,11,12,14,43) and 'o' ring (13).

Note: Ensure you do not damage piston rod (41) during disassembly or assembly.

- 9) Remove the top adapter and piston seal assembly (15,42,16) from the piston rod.

- 10) Carefully remove circlip (16) and piston rod seal (42) from the top adapter (15).
- 11) Remove cover (17) and silencer (40).
- 12) Clean and inspect all parts. Replace any suspect, worn or damaged components.
- 13) Assembly is the reversal of disassembly.

Note: Use Loctite 222 (or similar retaining compound) on the piston rod bolt thread (7) and the three Allen screws (5) when re-assembling the air motor.

Complete Pump Disassembly:

- 1) Disconnect air supply and release oil line pressure.
- 2) Remove oil discharge hose from pump outlet.
- 3) Withdraw pump from the oil drum/tank. (Use a clean bench to carry out maintenance).
- 4) Hold air motor housing firmly in a vice and carefully unscrew and remove the pump tube (20) assembly.

Note: Care should be taken not damage air motor housing during disassembly.

- 5) Remove 4 screws (44) from the air motor housing (2).
- 6) Remove the buffer spring (1) and buffer stopper (3) from air motor housing (2).
- 7) Push the air motor and piston rod assembly downwards into the pump tube (20) to enable easy disassembly of the air motor.
- 8) Remove the three Allen screws (5) and washers (5A) from the air valve assembly, then remove air valve cap (6).
- 9) Lift up the cover (17) to expose the exhaust holes located on the piston rod (41).
- 10) To retain the piston rod (41), insert the correct size steel bar or pin punch into one of the exhaust holes on the piston rod (41).

Note : Ensure you do not damage Piston Rod (41) during disassembly and assembly.

- 11) Unscrew the piston rod bolt (7), and remove the Air Valve Assembly (8,9,10,11,12,14,43) and 'o'ring (13).
- 12) Remove the top adapter and piston seal Assembly (15,42,16) from the piston rod.
- 13) Carefully remove circlip (16) and piston rod seal (42) from the top adapter (15).
- 14) Remove cover (17) and silencer (40).

- 15) Using a suitable size pin punch (1/8") remove the roll pin (36) from the Piston rod (41).
- 16) Unscrew and remove the connecting rod (35) and plunger assembly from the piston rod (41).
- 17) Dismantle plunger assembly.
- 18) Remove the piston rod (41) from the bottom adapter (18).
- 19) Remove circlip (39) from the bottom adapter (18) and remove oil seal assembly (37).
- 20) Remove foot valve (28) from the pump tube (20)
- 21) Dismantle foot valve assembly.

REASSEMBLY

- 1) Clean and inspect all parts. Replace any, suspect, worn or damaged parts.
- 2) Ensure that all parts have the correct orientation. If parts are assembled upside down, the pump will not work. Check the parts diagram for correct orientation.

Note: Use Loctite 222 (or similar retaining compound) on the piston rod bolt thread (7) and the three Allen screws (5) when re-assembling air motor.

Ensure correct orientation when fitting the seal carrier (37C), place the chamfer side into the bottom adapter first, be careful you do not damage the seal during assembly.

- 3) Assembly of the pump is a reversal of the disassembly procedure.
- 4) Fit the pump to your drum/tank and re-connect the oil hose and air supply. Open dispensing nozzle to ensure correct operation.

PARTS DIAGRAM for the R100THG (Hose and Gun Assembly)

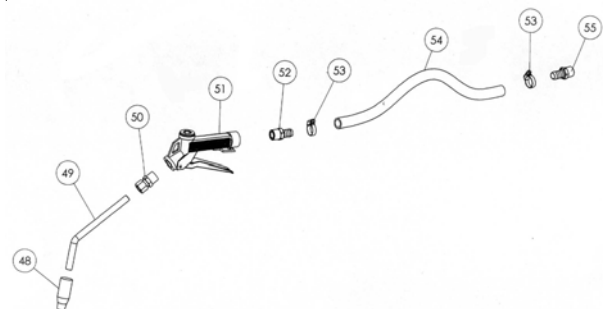

R100 PARTS LIST

ORDER FOR REPLACEMENT				
ITEM	PART No.	No. off	PART/SET No	DESCRIPTION
			TE01-1K (KIT A)	AIR MOTOR SERVICE KIT
			TE01-2K (KIT B)	PUMP SEAL KIT
			TE031As (KIT C)	OIL SEAL ASSEMBLY
1	TE002	1	TE002s incl TE003	A & B BUFFER SPRING
2	TE001	1	TE001s	AIR MOTOR HOUSING
3	TE003	1	order TE002s	A & B BUFFER STOPPER
4	N47	3	N47s	A SCREW
5	N117	3		A WASHER
6	TE011	1	TE011s	A & B AIR VALVE CAP
7	TE012	1		A PISTON ROD BOLT
8	TE013	2	TE013s	A PISTON WASHER
9	TE041	1		A & B AIR PISTON SEAL
10	TE030	3		A AIR VALVE SPACER
11	TE015	1		A AIR VALVE WASHER
12	TC36	1		A PISTON ROD SPACER
13	BS034	1		A & B O'RING
14	TC38	1		A & B PISTON SPRING
15	TE005	1	TE005s	TOP ADAPTOR (BSP)
15	TE032	1	TE032s	TOP ADAPTOR (NPT)
16	TE034	1		B CIRCLIP
17	TE006	1	TE006s	COVER
18	TE007	1	TE007s	BOTTOM ADAPTOR (BSP)
18	TE033	1	TE033s	BOTTOM ADAPTOR (NPT)
19	TE035	1	TE035s	B GASKET
20	TC6	1	TC6s	PUMP TUBE (DRUM)
20	TE027	1	TE027s	PUMP TUBE (STUB)
21	TE026	1		STAR NUT
22	TE025	1	TE025s	CLAMPING RING
23	TE024	1		LOWER BUNG NUT
24	TC40	1	order TC43s	B SPRING
25	TE010	1		SPRING CLIP
26	BS133	1	TE010s	B O'RING
27	TE009	1		WASHER
28	TE008	1	TE008s	FOOTVALVE (DRUM)
28	TE028	1	TE028s	FOOTVALVE (BSP/STUB)
28	TE037	1	TE037s	FOOTVALVE (NPT/STUB)
29	N209	1		B NUT
30	N140	1		B SPRING WASHER
31	TC43	1	TC43s	PLUNGER
32	BS223	1		B O'RING
33	TC41	1		WASHER
34	N350	1		B SPRING PIN
35	TC12	1	TC12s	CONNECTING ROD (DRUM)
35	TE029	1	TE029s	CONNECTING ROD (STUB)
36	N350	1		B SPRING PIN
37	TE031A	1	TE031As	C OIL SEAL ASSEMBLY
38	BS225	1		B O'RING
39	N247	1		B CIRCLIP
40	TE020	1	TE020s	SILENCER
41	TE017	1	TE017s	PISTON ROD
42	TE019	1		B PISTON ROD SEAL
43	TC39	1		A RETAINING WASHER
44	TE004	4	TE004s	SCREW
48	TD100	1	TD100s	NOZZLE ASSEMBLY
49	TD3	1	TD3s incl TD100s	FLEXIBLE EXTENTION
49	TC18	1	TC18s incl TD100s	RIGID EXTENTION
50	TD85	1	TD85s	ADAPTOR
51	TD40-1	1	TD40s	GUN BODY
52	N397	1	N397s	HOSE TAIL
53	N371	2	N371s	HOSE CLAMP
54	TA31	1	TA31s	HOSE
55	N394	1	N394s	HOSE TAIL

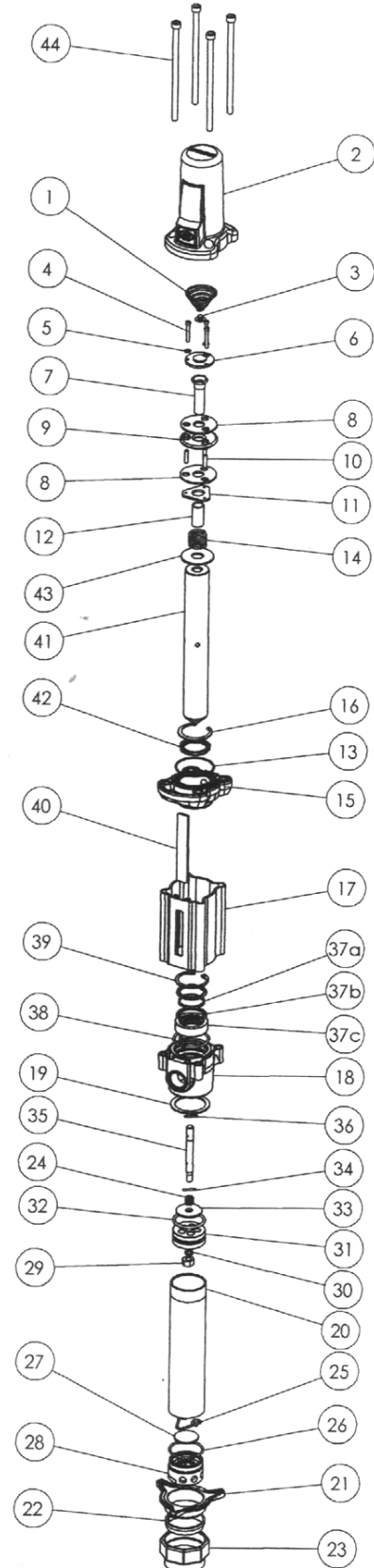

R300 PARTS LIST

			ORDER FOR REPLACEMENT			
ITEM	PART No	No. off	PART/SET No	KIT. REF	DESCRIPTION	
			TE01-1K (KIT A)		AIR MOTOR SERVICE KIT	
			TF01-2K (KIT B)		PUMP SEAL KIT	
			TF015As (KIT C)		OIL SEAL ASSEMBLY	
1	TE002	1	TE002s incl TE003	A & B	BUFFER SPRING	
2	TE001	1	TE001s		AIR MOTOR HOUSING	
3	TE003	1	order TE002s	A & B	BUFFER STOPPER	
4	N47	3	N47s	A	SCREW	
5	N117	3		A	WASHER	
6	TE011	1	TE011s	A & B	AIR VALVE CAP	
7	TE012	1		A	PISTON ROD BOLT	
8	TE013	2	TE013s	A	PISTON WASHER	
9	TE014	1		A & B	AIR PISTON SEAL	
10	TE030	3		A	AIR VALVE SPACER	
11	TE015	1		A	AIR VALVE WASHER	
12	TC36	1		A	PISTON ROD SPACER	
13	BS034	1		A & B	O'RING	
14	TC38	1		A & B	PISTON SPRING	
15	TE005	1	TE005s		TOP ADAPTOR (BSP)	
15	TE032	1	TE032s		TOP ADAPTOR (NPT)	
16	TE034	1		B	CIRCLIP	
17	TE006	1	TE006s		COVER	
18	TF009	1	TF009s		BOTTOM ADAPTOR (BSP)	
18	TF018	1	TF018s		BOTTOM ADAPTOR (NPT)	
19	N415	2		B	STEEL BALL	
20	TF001	1	TF001s		PUMP TUBE (STUB)	
20	TF012	1	TF012s		PUMP TUBE (DRUM)	
21	TE026	1	TF011s		STAR NUT	
22	TF011	1				CLAMPING RING
23	TE024	1				LOWER BUNG NUT
24	TC40	1			B	SPRING
25	TF005	1	TF005s		VALVE SEAT	
26	BS024	1		B	O'RING	
27	TD35	1		B	SPRING	
28	TF002	1	TF002s		FOOT VALVE (BSP/STUB)	
28	TF017	1	TF017s		FOOT VALVE (NPT/STUB)	
28	TF013	1	TF013s		FOOT VALVE (DRUM)	
29	N333	1		B	PIN	
30	TF016	1		B	PLUNGER SEAL	
31	TF006	1	TF006s		PLUNGER	
32	TD32	2	TD32s		WASHER	
33	N/A	1				
34	N349	1		B	PIN	
35	TF004	1	TF004s		CONNECTING ROD (STUB)	
35	TF014	1	TF014s		CONNECTING ROD (DRUM)	
36	N350	1		B	PIN	
37	TF015A	1	TF015As	C	OIL SEAL ASSEMBLY	
38	BS225	1		B	O'RING	
39	N247	1		B	CIRCLIP	
40	TE020	1	TE020s		SILENCER	
41	TF003	1	TF003s		PISTON ROD	
42	TE019	1		B	PISTON ROD SEAL	
43	TC39	1		A	RETAINING WASHER	
44	TE004	4	TE004s		SCREW	

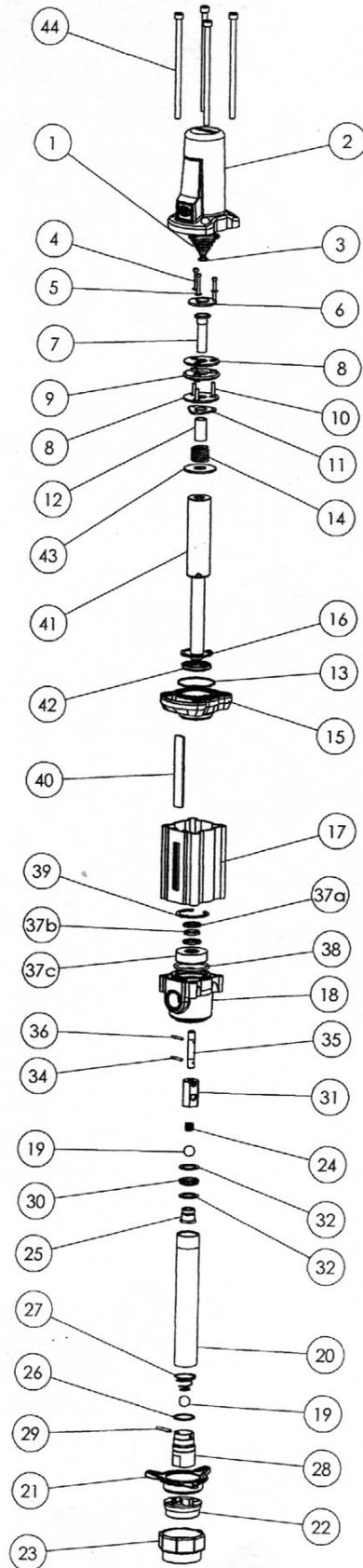

TROUBLE SHOOTING GUIDE

TROUBLE	CAUSE	REMEDY
Air motor operates without pressing gun trigger	1. Drum or tank is empty.	1) Change drum or fill tank.
	2. Foreign matter in footvalve (28).	2) Remove footvalve, clean and reassemble.
Air motor operates but little or no oil flows.	1. Drum or tank is empty..	1) Change drum or fill tank.
	2. Foreign matter in footvalve (28).	2) Remove footvalve, clean and reassemble.
	3. Faulty plunger (31) assembly.	3) Inspect plunger assembly replace any damaged or faulty parts.
Air continuously leaks through exhaust.	1. Piston rod seal (42) worn (or damaged).	1) Replace piston seal.
	2. Air valve worn or damaged.	2) Replace air valve assembly (Order TE01-1K).
Oil leaks through exhaust	Oil seal (37) is worn or damaged.	Replace oil seal assembly. (For R100 Order TE031As) (For R300 Order TF015As)
Pump is operating erratically and has air in the oil.	1. Suction tube is sucking air.	1) Re-seal suction tube. (Use either Teflon tape or a suitable thread sealant)
	2. Pump tube (20) is sucking air.	2) Re-seal pump tube. (Use either, Teflon tape or a suitable thread sealant)
Air motor does not operate when air is applied	Air valve cap is damaged or faulty	Replace air valve cap (6).

SPECIFICATIONS

	R100 (1:1Ratio)	R300 (3:1Ratio)
Maximum Air Pressure:	10.3 BAR/ 1035 kPa/ 150 PSI	10.3 BAR/ 1035 kPa/ 150 PSI
Minimum Air Pressure:	4BAR/ 400 kPa/ 60 PSI	4 BAR/ 400 kPa/ 60 PSI
Air Consumption:	0.09 m ³ / min (3 cfm)	0.09 m ³ / min (3 cfm)
Output (At The Pump):	60 Litres/ min (16 U.S. Gallons/ min) (SAE 10 @ 20°C using 10 BAR / 1000kPa / 145 PSI)	25 Litres/ min (6.5 U.S. Gallons/ min) (SAE 10 @ 20°C using 10 BAR / 1000kPa / 145PSI)
Maximum Static Head:	100m (328ft) (SAE 10 @ 20°C using 10 BAR / 1000kPa / 145 PSI)	300m (984ft) (SAE 10 @ 20°C using 10 BAR / 1000kPa / 145PSI)
Air Inlet Thread:	¼" BSP (F) or ¼" NPT (F)	¼" BSP (F) or ¼" NPT (F)
Pump Outlet Thread:	¾" BSP (F) or ¾" NPT (F)	¾" BSP (F) or ¾" NPT (F)
Bung Adapter Thread:	2" (Male)	2" (Male)
Suction tube Length:	Drum Pump 910mm (36") Stub Pump 220mm (8.7")	Drum Pump 900mm (35.4") Stub Pump 210mm (8.3")
Wetted components:	Aluminium, Brass, Zinc, Carbon Steel, Nitrile Rubber	Aluminium, Brass, Zinc, Carbon Steel, Nitrile Rubber
Foot Valve inlet thread:	Stub pump 1" BSP (1" NPT USA/Canada)	Stub pump ¾"BSP (3/4" NPT USA/Canada)



Macnaught Pty Ltd
PO Box 90 Amcliffe NSW 2205 Australia
Telephone (02) 9567 0401
Facsimile (02) 9597 7773
Email: sales@macnaught.com.au
Web: www.macnaught.com.au

macnaught warranty



- Macnaught Pty Ltd ("Macnaught") warrants that all products manufactured by Macnaught and/or supplied by Macnaught under the "Macnaught" brand, excluding M-Series positive displacement meters ("Meters") and components subject to wear, will be free from any defects caused by faulty materials or workmanship ("Warranty") for a period of 5 years from the date of purchase of the product.
- For products (excluding Meters) which carry the "Macnaughtdesign" endorsement, an additional Warranty period of 5 years applies to all mechanical components (excluding electronic and electrical components), giving a total Warranty period of 10 years.
- For Meters, the Warranty period is 12 months from the date of purchase of the product.
- For components contained in all products which are usually subject to wear from normal operation of the products (such as o-rings, seals, springs, hoses and batteries), the Warranty period is 12 months from the date of purchase of the relevant product.
- For products and components which are not manufactured by Macnaught and are supplied by Macnaught under a brand name other than "Macnaught", the Warranty period is the longer of 12 months from the date of purchase of the relevant product and the period of the manufacturer's warranty.
- The warranties contained in clauses 1, 2, 3, 4 and 5 above are conditional on the purchaser, during the relevant Warranty period:
 - delivering to Macnaught a detailed notice setting out full details of any defect in any product and details of the date and place of purchase (together with copies of purchase receipts and/or other supporting documents), and
 - at the purchaser's own cost, returning the defective product to the nearest authorised Macnaught service centre.
- Subject to compliance by the purchaser with clause 6, Macnaught shall, at its option, repair or replace any product or component found defective by its inspection by reason of faulty materials or workmanship of Macnaught.
- This Warranty does not cover the failure of products, parts or components which, in the sole judgment of the Macnaught, arises other than from faulty materials or workmanship of Macnaught, including misuse, abrasion, corrosion, negligence, accident, substitution of non-Macnaught parts, unauthorised modification, improper use, storage or handling, faulty installation or tampering by the purchaser or any third party.
- If Macnaught's inspection discloses no defect in material or workmanship, repair or replacement and return (at Macnaught's sole option) will be made at customary charges, which will be advised to the purchaser.
- Macnaught's liability and the purchaser's rights under this Warranty shall be limited to the repair or replacement of defective products or components and particular, shall not extend to any direct, special, indirect or consequential damage or losses of any other warranties.
- The foregoing Warranty supersedes, voids and is in lieu of any other warranties.
- This Warranty does not form part of, nor does it constitute, a contract between Macnaught and the end-user or purchaser. It is additional to any warranty given by the seller of the products. This Warranty does not exclude, limit, restrict or modify the non-excludable rights or remedies conferred upon the end-user or purchaser, or the non-excludable duties or liabilities imposed on the seller or Macnaught, by Part V, Division 2, 2A, and Part VA of the Trade Act 1974 (Commonwealth) or other rights conferred on the end-user or purchaser or duties or liabilities imposed upon Macnaught.