

#### Description

The 5005AN refueling drum pump is designed for the transfer of fuels and lubricants up to SAE30. This economical and hard working drum pump has a delivery rate of approximately 1 litre per stroke or approximately 40 litres per minute. Lightweight, the pump is supplied with 2.4 metres of delivery hose, a versatile metal delivery spout and a spout holster. The simple and proven design of the 5005AN makes this pump the ideal drum pump for fuel and lubricant transfer in challenging and harsh operating environments.

#### Specifications

Use	Petrol, diesel, kerosene and lubricants up to SAE30 from 60 or 205 litre drums
Discharge Volume	40 litres per minute or 1 litre per stroke
Inlet/Outlet	Inlet: 1" BSP Outlet: 1" BSP
Hose	2.4 metres of 1" ID fuel resistant hose
Materials	Aluminium handle, aluminium body with POM piston and piston rings

#### Fitting the telescopic downtube to the pump

Screw the downtube to the pump, carefully applying the thread tape to the thread on the downtube to ensure there are no air leaks between the downtube and the pump inlet whilst securing the downtube firmly in place.

#### Fitting the pump to the drum or tank

- 1 Pull out the short tube to the fully extended position then place the pump in the drum or tank.
- 2 Screw the pump to the drum or tank firmly.

#### Fitting the hose to the pump (Sequence Is Important)

- 1 Place the hose & spout in the hose holster. (The locking pin on the spout engages in the keyway at the extreme left of the holsters opening).
- 2 Turn the spout fully clockwise to ensure that when fully assembled, the nozzle locking pin rests vertically within the holster.
- 3 Fit the hose clamp loosely to the end of the hose and slide the spring down onto the hose.
- 4 Push the hose end onto the pump outlet, slide the hose clamp over the hose at the outlet and tighten. Slide the hose spring up against the hose clamp. Check that the spout locking pin is still in a vertical position inside the holster. If not, adjust the hose position on the spout to correct this.

#### Pump Operation

When the handle is pulled back, the piston is pushed up by the con rod and the valve closes. At the same time fuel or lubricant on the top of the piston is discharged through the hose. When the handle is pushed forward, the piston is pulled down by the cross bar and the valve is opened. The fuel or lubricant then flows past the valve through the centre of the piston and fills the cylinder above the piston. The inlet valve is closed during this stroke.



# Parts and Drawing Breakdown For The 5005AN

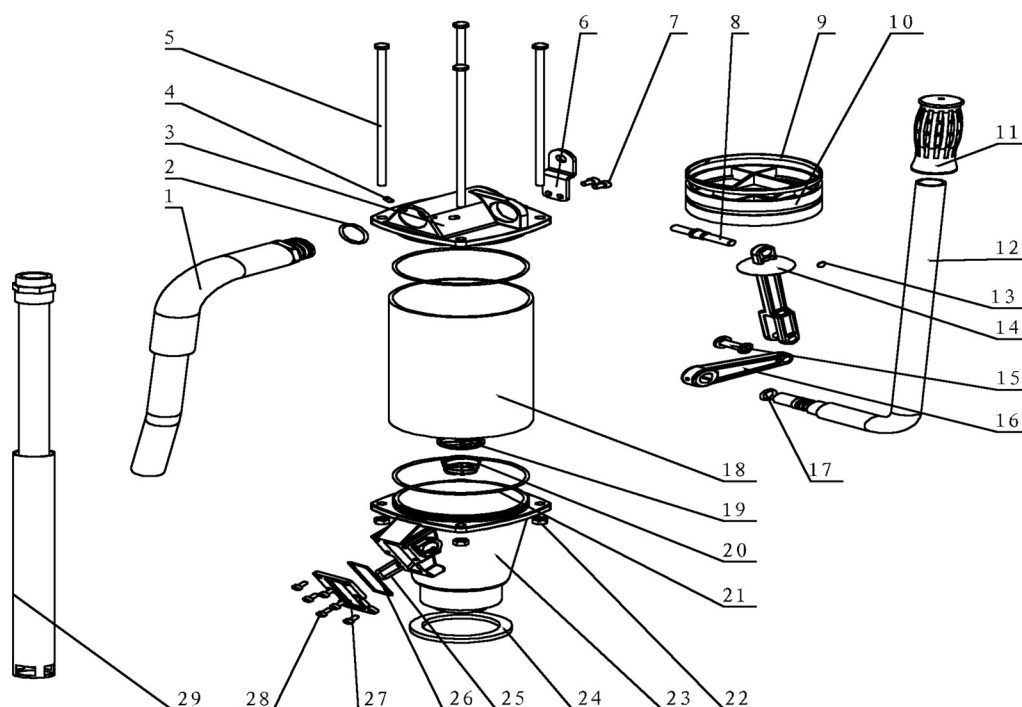

## Ordering Spare Parts

### Parts List – Part No. 5005AN

ITEM	DESCRIPTION	QTY	ITEM	DESCRIPTION	QTY
5005AN-1	Hose Set	1	5005AN-16	Clevis	1
5005AN-2	O Ring	1	5005AN-17	O Ring Gland	1
5005AN-3	Body - Upper Assembly	1	5005AN-18	Cylinder	1
5005AN-4	Hex Screw	2	5005AN-19	Inlet Valve	1
5005AN-5	Bolts Set	4	5005AN-20	Spring	1
5005AN-6	Plate	1	5005AN-21	O Ring	2
5005AN-7	Hex Screw	2	5005AN-22	Nuts	4
5005AN-8	Cross Bar	1	5005AN-23	Body - Lower Assembly	1
5005AN-9	Washer	1	5005AN-24	Locking Pin	1
5005AN-10	Piston	1	5005AN-25	Pin	1
5005AN-11	Knob	1	5005AN-26	O Ring	1
5005AN-12	Pump Handle	1	5005AN-27	Cover	1
5005AN-13	Bearing Spring	1	5005AN-28	Pan Head Screw	6
5005AN-14	Connecting Rod Assembly	1	5005AN-29	Down Tube	1
5005AN-15	Clevis Screw	1			

## Trouble Shooting

TROUBLE	CAUSE	REMEDY
Fuel leaks at the retainer plate	O Ring seal worn or damaged	Replace O Ring
Handle is loose and unit will not pump	Clevis is broken or the connecting rod pin is dislodged	Replace the clevis or locking pin
Pump continues to syphon even after one stops pumping the handle	Spout is lower than the container	Return spout to spout holster
Pump fails to prime	The piston rings are worn out	Replace piston rings
Pump fails to prime	The downtube and the pump head thread connections are not airtight	Reconnect the threads using thread tape
Experiencing problems priming the pump	Air in the downtube, pump head and hose assembly	Ten to fifteen long, hard strokes of the handle are needed to prime the pump

NSW TEL: (02) 9939 0711 FAX: (02) 9939 0411	QLD/PNG TEL: (07) 3889 8480 FAX: (07) 3889 8490	VIC/TAS TEL: (03) 8787 8288 FAX: (03) 8787 8266	WA TEL: (08) 9209 3066 FAX: (08) 9209 3933	SA/NT TEL: (08) 8241 7111 FAX: (08) 8241 7011	NZ TEL: (09) 447 1007 FAX: (09) 447 1008
---	---	---	--	---	--