

BREATHERS:

VentGuards

The ideal solution to protect against moisture and particulate contamination in low-flow applications with intermittent operations.



APPLICATIONS:

- Gearboxes
- Low-Flow
- High-Humidity
- Washdown



Lube Control Pty Ltd

Providing lubrication solutions!

www.lubecontrol.com.au
sales@lubecontrol.com.au

Australia Wide 1300 917 946
from outside Australia +61 8 8298 5563



The Overview

Standard Breathers: Typical Industries

- Wind Energy
- Pulp & Paper
- Aviation
- Storage
- Manufacturing
- PetroChemical

By the Numbers:

1-Recessed Check-Valves

High-quality umbrella check-valves that won't clog or stick are recessed underneath the unit for added protection from washdown environments. Check-valves isolate equipment from ambient conditions, prolonging breather life.

2-Integrated Nylon Standpipe

The integrated standpipe provides excellent vibration resistance and dissipates impact throughout the unit, eliminating weak points. It also allows even airflow distribution throughout the unit, eliminating inaccurate readings of desiccant saturation.

3-Resilient Polycarbonate Body

Shock-absorbing, clear casing provides reliable service and easy maintenance.

4-Filter Element

Polyester filter element removes airborne contamination to 3-micron absolute. Unique loops allow particles to release during system exhalation, helping to increase breather life.

5-Water Adsorbent

Silica gel adsorbs water from incoming air and can hold up to 40% of its weight. Condition is indicated by change of color from blue to light pink.

6-Secondary Filter Element

Second polyester filter element protects against migration of desiccant dust, providing maximum efficiency.

7-Foam Pad

Foam filter captures any oil mist and disperses incoming air evenly over filtration and drying areas.

8-Threaded Mounting

Easily replaces standard filler/breather cap with multi-fit connection or one of several adapters.

How It Works

This breather unit replaces the standard dust cap or OEM breather cap on equipment. Check-valves on the bottom of the unit isolate the system until equipment needs to breathe. As air is drawn into equipment through the breather, the layered filter elements remove particulate while the desiccant beads strip harmful moisture.

While in service or during shutdown, the desiccant beads attract moisture from inside the equipment reservoir, actively drying the equipment.

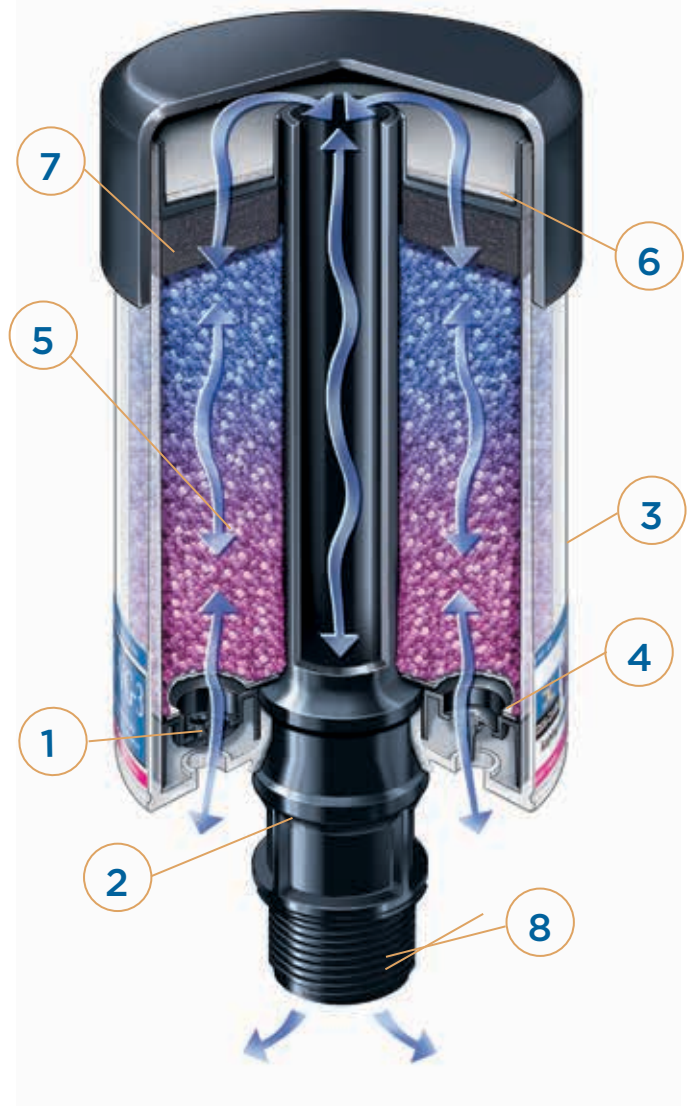

Charts & Graphs

Materials & Components:

Filter Housing: Polycarbonate, nylon, polypropylene, Buna-N, silicone

Filter Media: Polyurethane, polyester

Hydrophilic Media: Silica gel

Filter Efficiency:

(3 μ absolute ($\beta_3 \geq 200$))

Recommended Temperature Range:

-20°F to 200°F

-29°C to 93°C

Chemical Compatibility:

Recommended:

All Gear Oils

Most Hydraulic Fluids

Mineral & Synthetic Oil

Not Recommended:

Phosphate Ester

Hydrogen Sulfide

Sulfuric Acid

Highly Alkaline Cleaners

Sizing Recommendations:

Model	Max. Airflow at 1psid	Recommended Max. Volume
		Gearbox/ Storage Tank
DC-VG-BB	1.45cfm/41lpm	15gal/57L
DC-VG-1	1.45cfm/41lpm	35gal/132L
DC-VG-2	2.44cfm/69lpm	200gal/757L
DC-VG-3	2.48cfm/70lpm	350gal/1325L
DC-VG-4	2.98cfm/84lpm	500gal/1893L

Water Adsorption Capacity:

Size	Maximum Water Retention
DC-VG-BB	23ml / 0.8fl. oz.
DC-VG-1	50ml / 1.68fl. oz.
DC-VG-2	118ml / 4fl. oz.
DC-VG-3	220ml / 7.45fl. oz.
DC-VG-4	353ml / 11.3 fl. oz.

Dimensions & Connections:

Model	Connection	Unit Height	Unit Width
DC-VG-BB	3/8" Multi-Fit (NPT, BSPP, BSPT)	3.90in	2.5in
		9.9cm	6.4cm
DC-VG-1	3/8" Multi-Fit (NPT, BSPP, BSPT)	5.351in	2.5in
		13.5cm	6.4cm
DC-VG-2	1" Multi-Fit (NPT, BSPP, NPSM)	6in	4.1in
		15.6cm	10.2cm
DC-VG-3	1" Multi-Fit (NPT, BSPP, NPSM)	8in	4.1in
		20.6cm	10.2cm
DC-VG-4	1" Multi-Fit (NPT, BSPP, NPSM)	10in	4.1in
		25.7cm	10.2cm

ADDITIONAL SPECS.

Airflow:

DC-VG-2

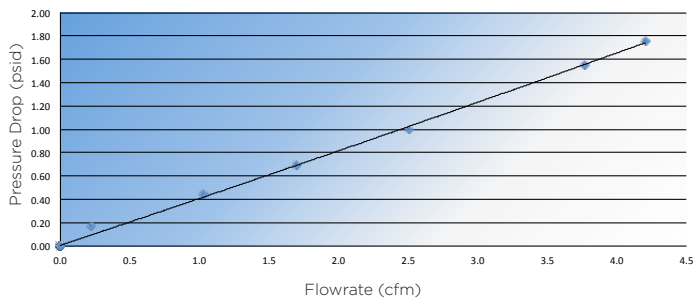

DC-VG-3

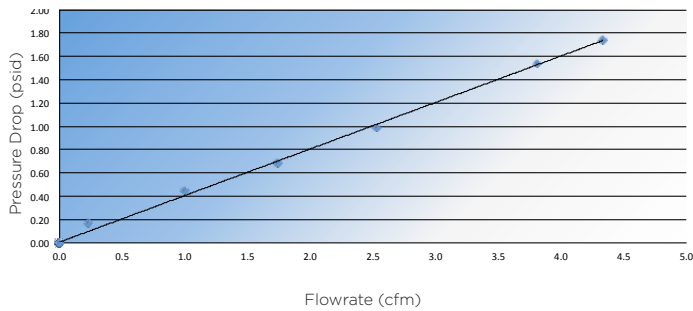

DC-VG-4

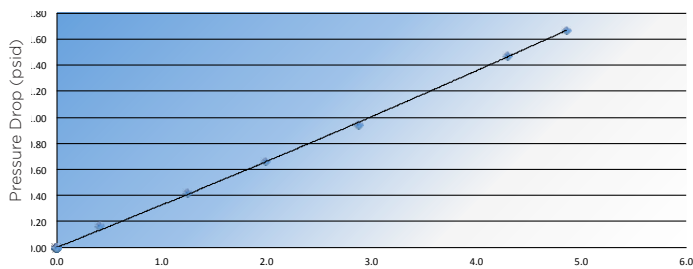

Miniatures:

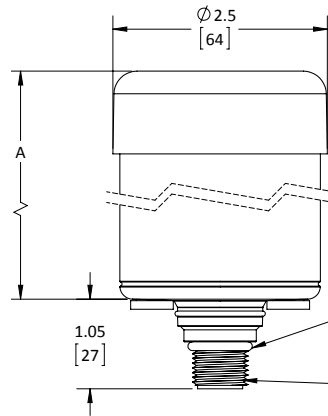

Breathers	A
DC-VG-BB	2.824
DC-VG-1	4.307

Standard Sizes:

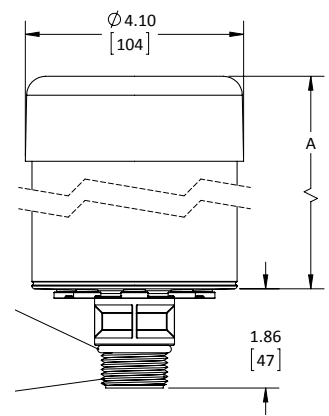

Breathers	A
DC-VG-2	4.13
DC-VG-3	6.13
DC-VG-4	8.13



LUBE
Control

Lube Control Pty Ltd

Providing lubrication solutions!

Australia wide

1300 917 946

+61 8 8298 5563

www.lubecontrol.com.au

sales@lubecontrol.com.au

Des-Case Corporation | 675 N. Main St. | Goodlettsville, TN 37072
D: 615.672.8800 | F: 615. 672.0701 | descase.com